

REV	DATE	REVISION DETAILS	INIT	IMPERIAL DIMENSIONS	LINK CONNECTORS Pty. Ltd.	A GORDON GROUP COMPANY
C	10.6.08	Redrawn in AutoCad.		NAME DATE	TITLE 'N' CRIMP CABLE PLUG for RG8 cable	
				DRAWN kwk 11.5.08		
				APPR'VD	MATERIAL NOTED	
					FINISH NOTED	
TOLERANCE UNLESS OTHERWISE SPECIFIED: 2 fig decimal +/- .004" 3 fig decimal +/- .002" Angles +/- 1 deg						DRAWING No. B30-130C
						ISSUE C
						REF. DRGS. B30-027C & 036C
						FIRST USE:
						SCALE 2:1

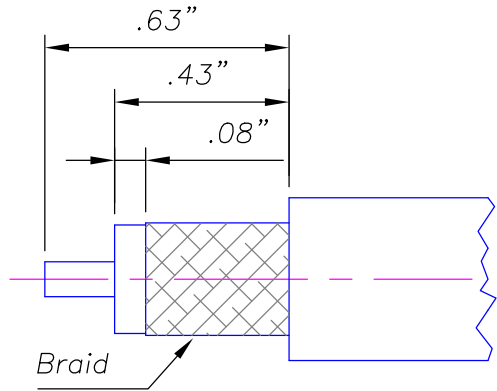

CABLE TRIMMING DETAILS  
For RG8, 213 & similar cables

Key	Part No.	DESCRIPTION	Qty.	Material	Finish
1	11888	SWIVEL NUT	1	Brass	Nickel Plate
2	12397	BODY	1	Brass	Nickel Plate
3	11889	GASKET	1	Silicon Rubber	Red
4	11890	CIRCLIP	1	Brass	Natural
5	12395	INSULATOR	1	P.T.F.E.	Natural
6	12084-8	CRIMP TAIL	1	Brass	Nickel Plate
7	12398-3	CRIMP/CAPTIVE PIN	1	Brass	Gold Plated
8	12090-8	CRIMP SLEEVE	1	Brass	Nickel Plate

