

REV	DATE	REVISION DETAILS	INIT	IMPERIAL DIMENSIONS		GORDON TECHNOLOGIES Pty. Ltd.	A GORDON GROUP COMPANY	B20-001		
D	6.10.09	Redrawn in AutoCad		NAME	DATE	TITLE			DRAWING No.	
				DRAWN	dgg	6.10.09	CABLE PLUG - TNC		ISSUE D	
				APPR'VD			MATERIAL NOTED		REF. DRGS. B20-014	
				X.XX/3.66 Metre bar			FINISH NOTED		FIRST USE: XXXXXXX	
				TOLERANCE UNLESS OTHERWISE SPECIFIED: 2 fig decimal +/- .004" 3 fig decimal +/- .002" Angles +/- 1 deg						SCALE 2:1

Key	Part No.	DESCRIPTION	Qty.	Material	Finish
1	11984	SWIVEL NUT	1	Brass	Nickel Plated
2	12477	INSULATOR	1	P.T.F.E.	Natural
3	12399-1	PIN - CONTACT	1	Brass	Gold Plated
4	11983	SEAL	1	Silicon Rubber	Natural
5	11986	CIRCLIP	1	Brass	Natural
6	11979-2	RETAINING RING	1	Brass	Nickel Plated
7	11960	BODY	1	Brass	Nickel Plated
8	11925-1	COLLET - BRAID	1	Brass	Nickel Plated
9	11925-1	GASKET - CABLE	1	Neoprene	Natural
10	11832-1	CABLE NUT	1	Brass	Nickel Plated

FOR RG58 CABLES

TNC interface to MIL STD 348A dimensions

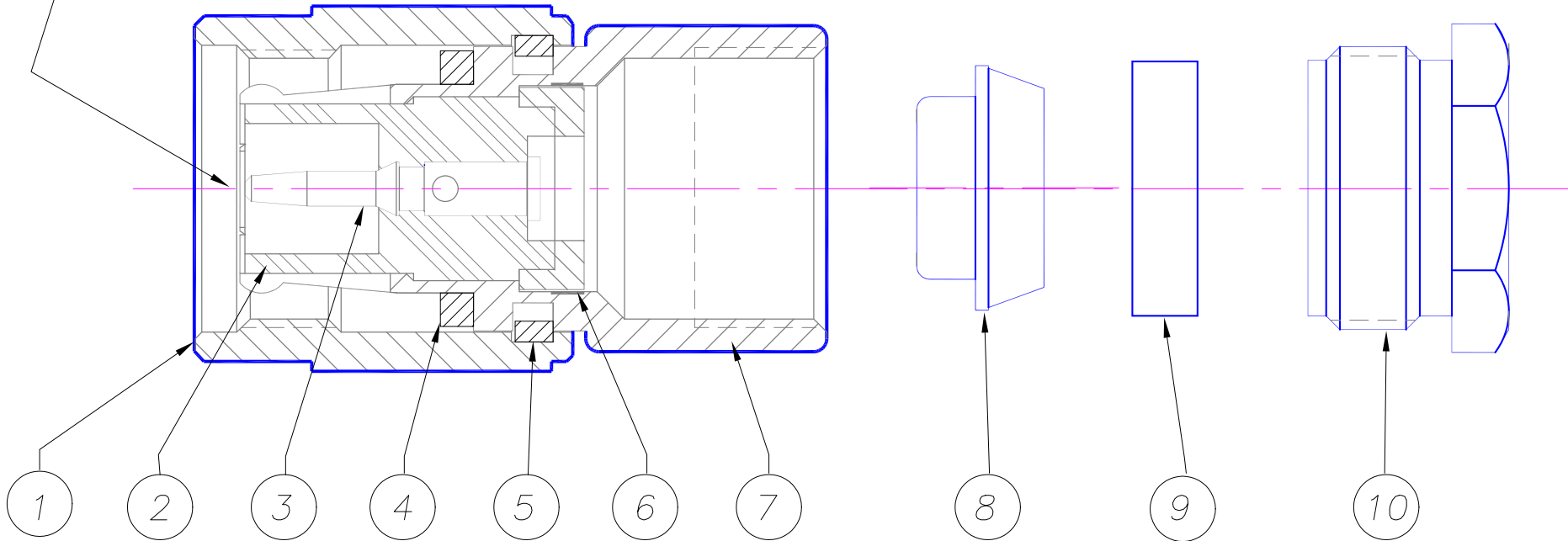

COPYRIGHT RESERVED: THIS DRAWING IS THE SOLE PROPERTY OF LINK CONNECTORS P/L & IS RETURNABLE ON REQUEST. IT IS TO BE TREATED AS CONFIDENTIAL, IS NOT TO BE COMMUNICATED TO ANY OTHER PERSON WITHOUT THE WRITTEN CONSENT OF LINK CONNECTORS & MAY BE USED FOR MANUFACTURE, ONLY WHEN ACCOMPANIED BY A WRITTEN ORDER.