

REV	DATE	REVISION DETAILS	INIT.	METRIC DIMENSIONS		GORDON TECHNOLOGIES P/L <small>A GORDON GROUP COMPANY</small>		<b>B10-090</b>	DRAWING No. <span style="float:right">ISSUE <b>B</b></span>
A	30.3.04	RELEASED.	kwk	NAME	DATE	TITLE			
B	10.6.08	A/Y Pt No added & branding deleted		DRAWN	kwk	03.02.04	'BNC' CABLE PLUG with Crimp termination & Captive Pin		REF. DRGS. B10-028
				APPRVD.	BWG	30.3.04	MATERIAL NOTED		FIRST USE
							FINISH NOTED		SCALE: 2:1
GENERAL TOLERANCE UNLESS OTHERWISE SPECIFIED: One fig. decimal +/- 0,20 Two fig. decimal +/- 0,05 Angles +/- 1 degree									

FOR CABLES - RG59 Large Cond. eg Belden #9259, 1505

Key	Part No.	DESCRIPTION	Qty.	Material	Finish
1	20-305-59-75	BODY/INSULATOR ASSY	1	BRASS/PTFE	Nickel Plated
2	AS SUPPLIED	CRIMP PIN	1	Brass	Gold Plated
3	AS SUPPLIED	CRIMP SLEEVE	1	Brass	Nickel Plated

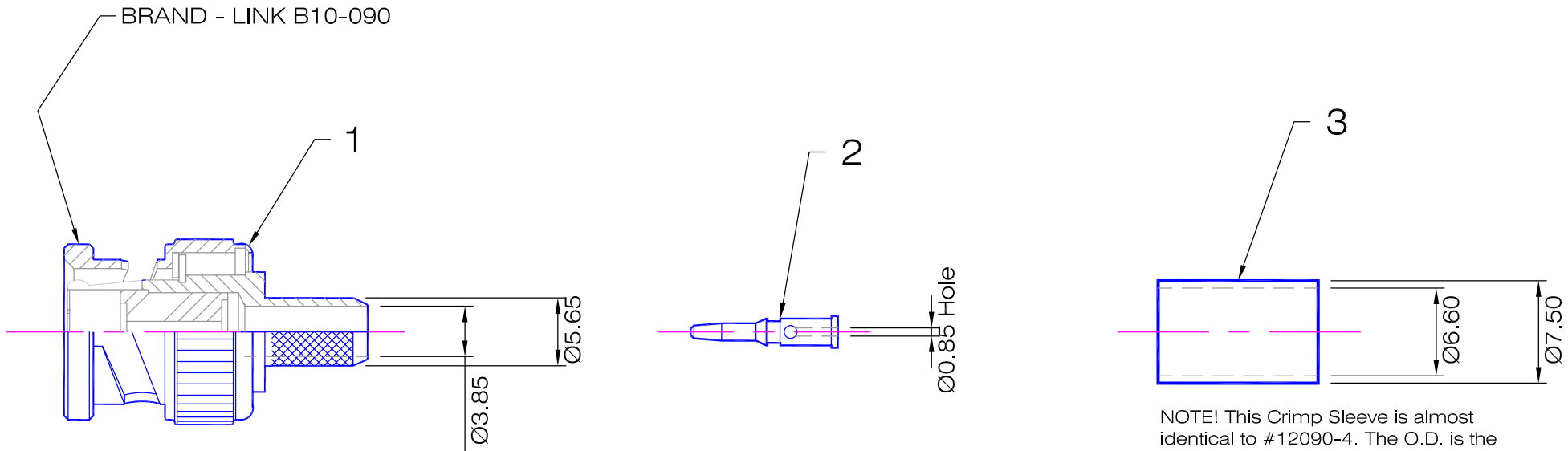

'BNC' INTERFACE TO MEET  
MIL STD 348A

NOTE! This Crimp Sleeve is almost identical to #12090-4. The O.D. is the same, the I.D. is slightly larger.  
DO NOT MIX WITH #12090-4 SLEEVES.

**NOTE ! 75 OHM CONNECTOR - RECESSED INSULATOR.**