

REV	DATE	REVISION DETAILS	INIT.	METRIC DIMENSIONS		LINK CONNECTORS P/L	A GORDON GROUP COMPANY	B10-037	C
C	.08	Redrawn AutoCad.		NAME	DATE	TITLE			
				DRAWN	kwk	28.4.08	'BNC' CABLE PLUG with Crimp termination & Captive Pin	DRAWING No.	ISSUE
				APPRVD.			MATERIAL NOTED	REF. DRGS. B10-029	
							FINISH NOTED	FIRST USE	
GENERAL TOLERANCE UNLESS OTHERWISE SPECIFIED: One fig. decimal +/- 0,20 Two fig. decimal +/- 0,05 Angles +/- 1 degree								SCALE: 2:1	

FOR CABLE - RG6, Belden #9248

Key	Part No.	DESCRIPTION	Qty.	Material	Finish
1	20-305-285	BODY/INSULATOR ASSY	1	BRASS/PTFE	Nickel Plated
2	12399-1	CRIMP PIN	1	Brass	Gold Plated
3	12090-3	CRIMP SLEEVE	1	Brass	Nickel Plated

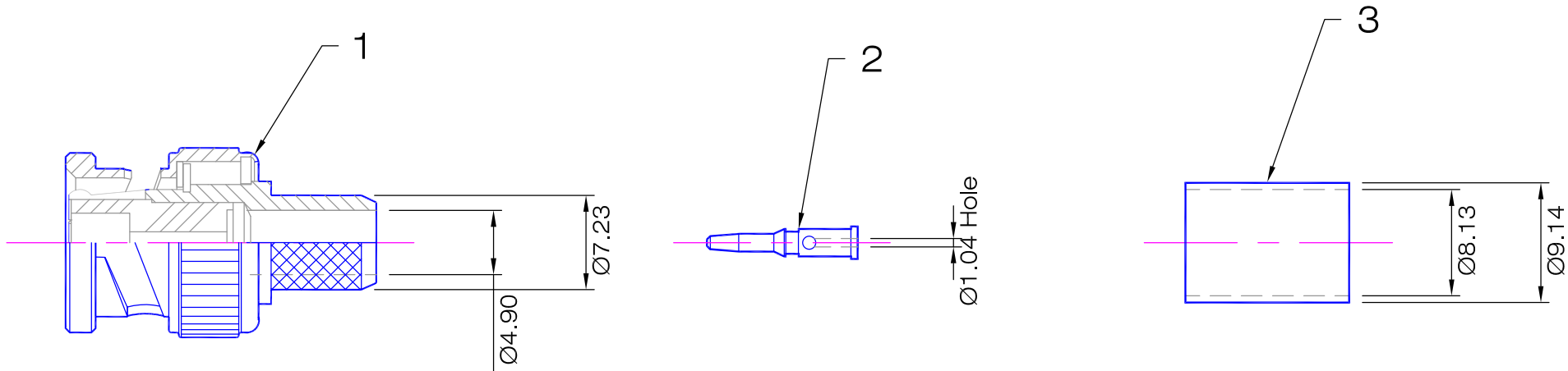

'BNC' INTERFACE TO MEET
MIL STD 348A

COPYRIGHT RESERVED: THIS DRAWING IS THE SOLE PROPERTY OF LINK CONNECTORS P/L & IS RETURNABLE ON REQUEST. IT IS TO BE TREATED AS CONFIDENTIAL, IS NOT TO BE COMMUNICATED TO ANY OTHER PERSON WITHOUT THE WRITTEN CONSENT OF LINK CONNECTORS & MAY BE USED FOR MANUFACTURE, ONLY WHEN ACCOMPANIED BY A WRITTEN ORDER.