

REV	DATE	REVISION DETAILS	INIT.	METRIC DIMENSIONS			LINK CONNECTORS P/L	A GORDON GROUP COMPANY	B10-028	F
E	30.1.01	Redrawn AutoCad. Item 1 was #284 Body assy.	kwk	NAME	DATE	TITLE		DRAWING No.		
F	10.6.08	Item 1 was #281 & branding deleted.		DRAWN	kwk	25.1.01	'BNC' CABLE PLUG with Crimp termination & Captive Pin			
				APPRVD.	BWG	30.1.01	MATERIAL NOTED	REF. DRGS.	B10-026	
							FINISH NOTED	FIRST USE		
GENERAL TOLERANCE UNLESS OTHERWISE SPECIFIED: One fig. decimal +/- 0,20 Two fig. decimal +/- 0,05 Angles +/- 1 degree								SCALE:	2:1	

FOR CABLES - Belden #9259, Hartland #HC4054

Key	Part No.	DESCRIPTION	Qty.	Material	Finish
1	20-305-59	BODY/INSULATOR ASSY	1	BRASS/PTFE	Nickel Plated
2	12399-3	CRIMP PIN	1	Brass	Gold Plated
3	12090-4	CRIMP SLEEVE	1	Brass	Nickel Plated

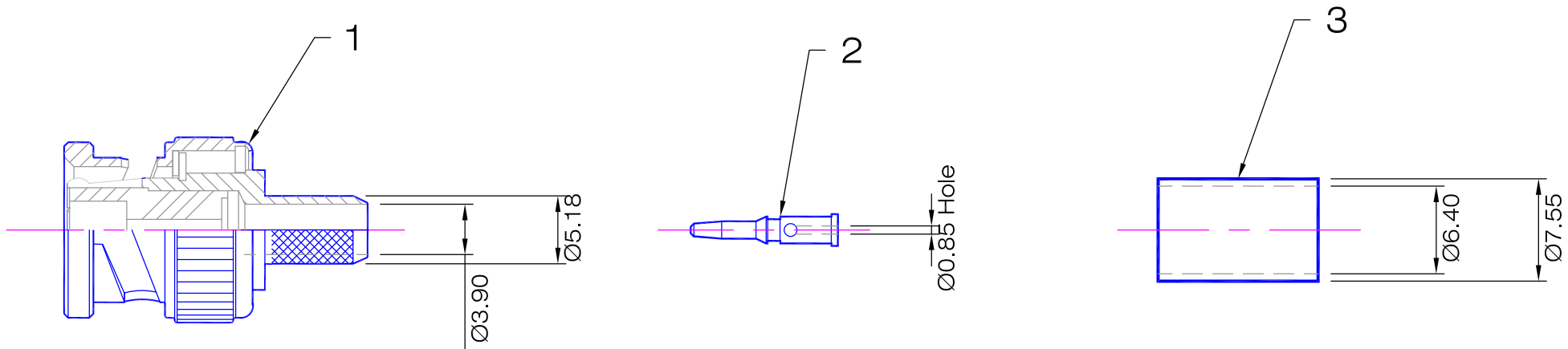

'BNC' INTERFACE TO MEET  
MIL STD 348A

NOTE ! THIS ASSEMBLY IS THE SAME AS B10-026 EXCEPT FOR ITEM #2 - CAPTIVE PIN.