

REV	DATE	REVISION DETAILS	INIT	IMPERIAL DIMENSIONS		GORDON TECHNOLOGIES Pty. Ltd. A GORDON GROUP COMPANY		B10-010		
C	.08	Redrawn in AutoCad.		NAME	DATE	TITLE			DRAWING No.	
				DRAWN	kwk	28.4.08	'BNC' J/J Adaptor B'hd Mnt #9		ISSUE C	
				APPR'VD			MATERIAL NOTED		REF. DRGS. B10-009 & -010	
							FINISH NOTED		FIRST USE:	
				TOLERANCE UNLESS OTHERWISE SPECIFIED: 2 fig decimal +/- .004" 3 fig decimal +/- .002" Angles +/- 1 deg						SCALE 2:1

Key	Part No.	DESCRIPTION	Qty.	Material	Finish
1	12407	BODY	1	Brass	Nickel Plated
2	12368-1	CONTACT - double ended	1	Be Cu	Gold Plated
3	12367	50 ohm INSULATOR	2	P.T.F.E	Natural
4	11012-3	Locknut	1	Brass	Nickel Plated

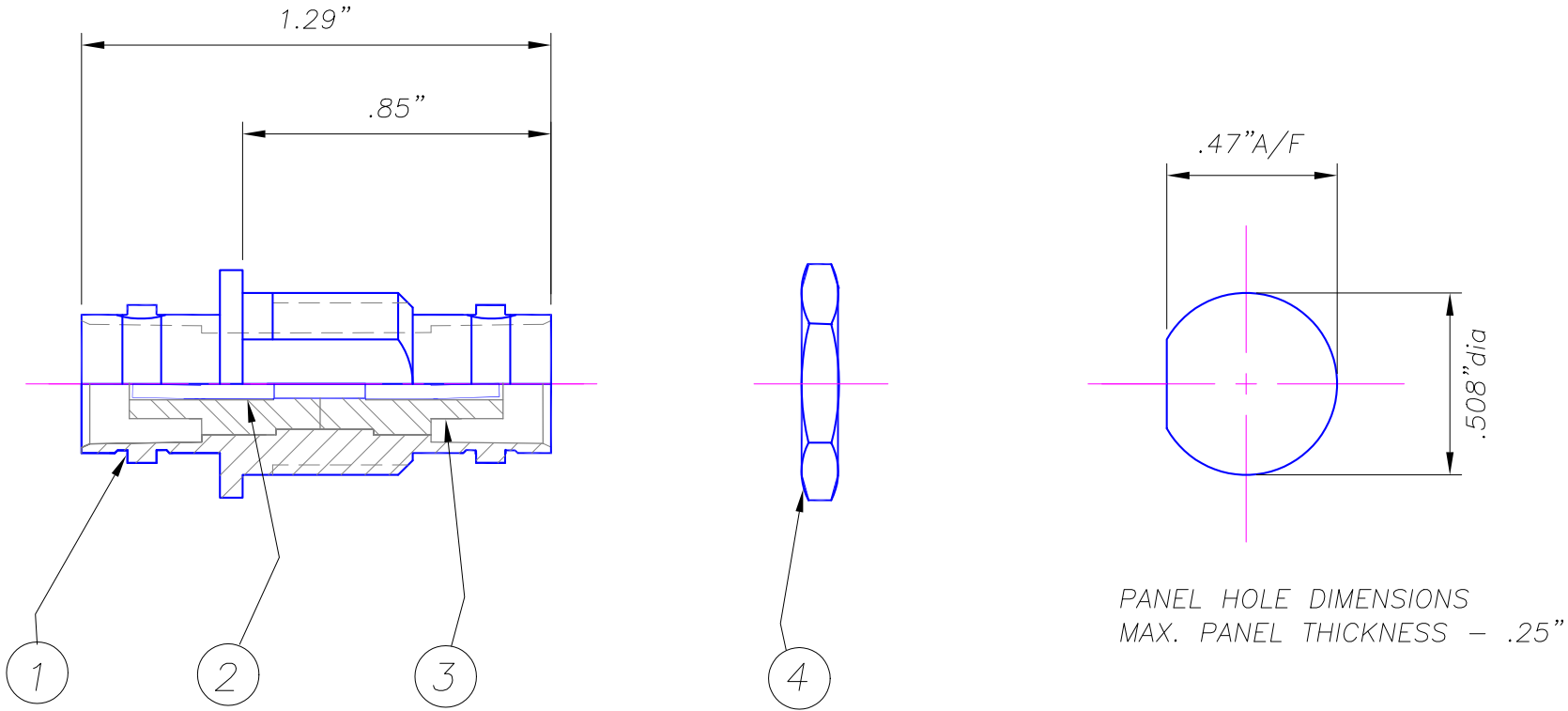

COPYRIGHT RESERVED: THIS DRAWING IS THE SOLE PROPERTY OF LINK CONNECTORS P/L & IS RETURNABLE ON REQUEST. IT IS TO BE TREATED AS CONFIDENTIAL, IS NOT TO BE COMMUNICATED TO ANY OTHER PERSON WITHOUT THE WRITTEN CONSENT OF LINK CONNECTORS & MAY BE USED FOR MANUFACTURE, ONLY WHEN ACCOMPANIED BY A WRITTEN ORDER.